



ECOMAK OTOMASYON SİSTEMLERİ
MAKİNA İMALAT SANAYİ LİMİTED ŞİRKETİ



ECOMAK MAKİNA

Başla



ECOMAK MAKİNA,

2018 yılında Bursa Küçük Sanayide 200 metrekare bir atölyede kurulmuş olup 2020 yılında 1000 metrekarelik yeni fabrikamızda hizmet vermeye başladık.

Her çeşit makine imalatı ve bakım hizmetlerinde, yılların birikimini, tecrübesini ve bilgisini en son teknolojiyle birleştiren ve müşterilerinin problemlerine kalıcı ve kaliteli çözümler üretmeyi görev bilmiş bir firmadır.

Firmamız, kaliteyi, güvenilirliği ve müşteri memnuniyetini temel çalışma felsefesi edinen bir firmadır. Kuruluşumuzun ilk ayından Bursa'daki farklı sektörlerdeki fabrikalarla çalışmaya başlayan firmamız, farklı tip makinalara çözüm önerileri getirerek müşteri portföyünü geliştirmeye başlamıştır.

Amacımız; yılların getirdiği mesleki tecrübemizle, müşterilerimiz ihtiyacını tam olarak anlayıp kendi kapasitemizle onlara ideal makina bakımı, makina imalatı ve yedek parça imalatı konusunda verimli ve tasarruflu bir biçimde sağlayıp uzun vadeli yol haritaları çizmelerine yardımcı olmaktır.





Fikstür İmalat

Kaynaklı İmalat

Makina Parkuru

YAPTIKLARIMIZ

Talaşlı İmalat

Montaj ve Şantiye
Kurulum Desteği



Tasarım

Robotlu Kaynak
Hücreleri

Fikstür İmalat



MANUEL FİKSTÜRLER

Parçaya Özel Tasarım

Ergonomik Çalışma İmkani

Anahtar Teslim Proje

Güvenlik Önlemleri

OTOMASYONLU FİKSTÜRLER

Otomasyon Ve Yazılım

Parçaya Özel Tasarım

İmalat Ve Montaj

Ergonomik Çalışma İmkani

Anahtar Teslim Proje

Güvenlik Önlemleri





Robot otomasyon sistemleri Anahtar teslim projeler:

Simülasyon aşamasından itibaren robot, otomasyon ve mekanik tecrübelerimizi birleştirerek mekatronik çözümler sunmaktayız. Tek çatı altında robotlu projelerin tüm bileşenlerini gerçekleştiriyoruz.

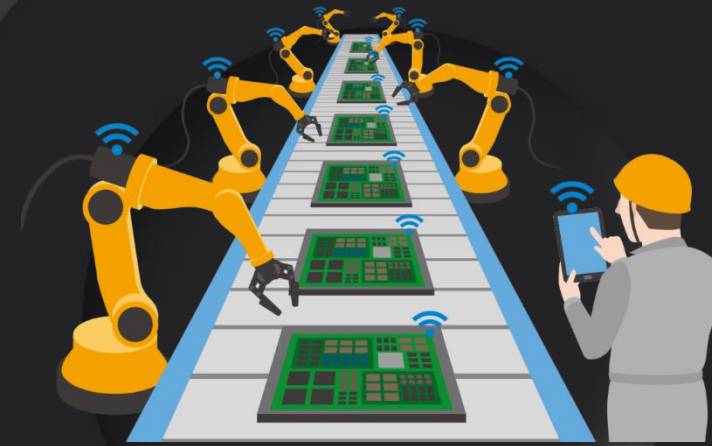

Robotlu Kaynak Hücreleri



ROBOTLU GAZALTI KAYNAK HÜCRESİ

ROBOTLU PUNTA KAYNAK HÜCRESİ

İstenilen Fikstür Boy Ve Ağırlığına Göre Tasarım Ve İmalat

Tek Parça Taşıma Kolaylığı

Toz Ve Dumandan Ayrıştırılmış Elektrik Kabını

Senkron Kaynak Yapabilme

Tasarım Ve Mühendislik

Anahtar Teslim Proje

Güvenlik Önlemleri

Robotlu Sistemler

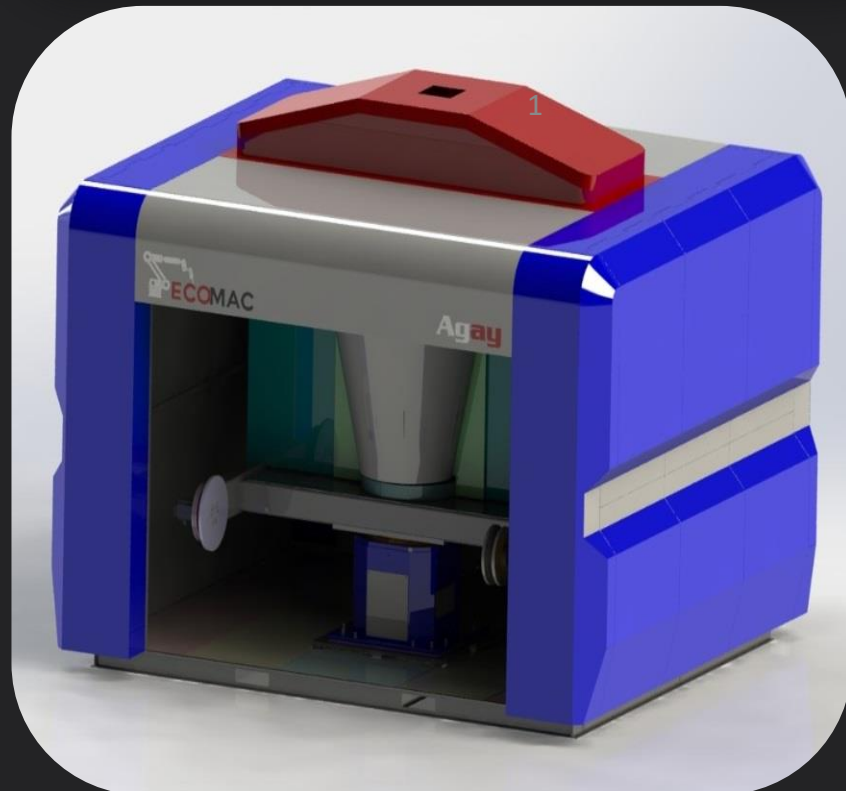
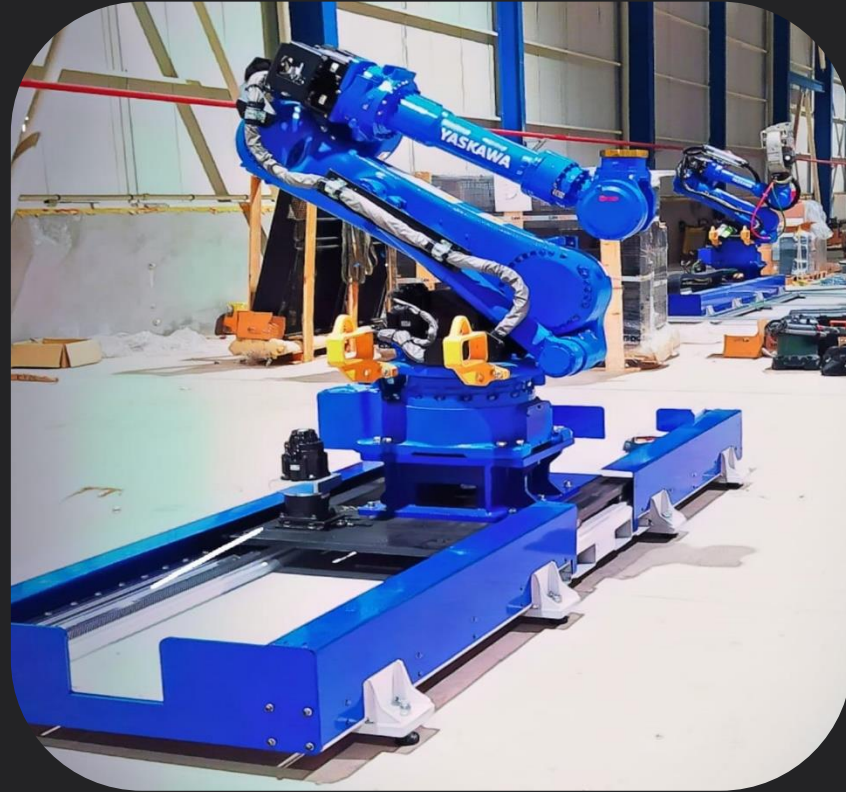



Tasarım

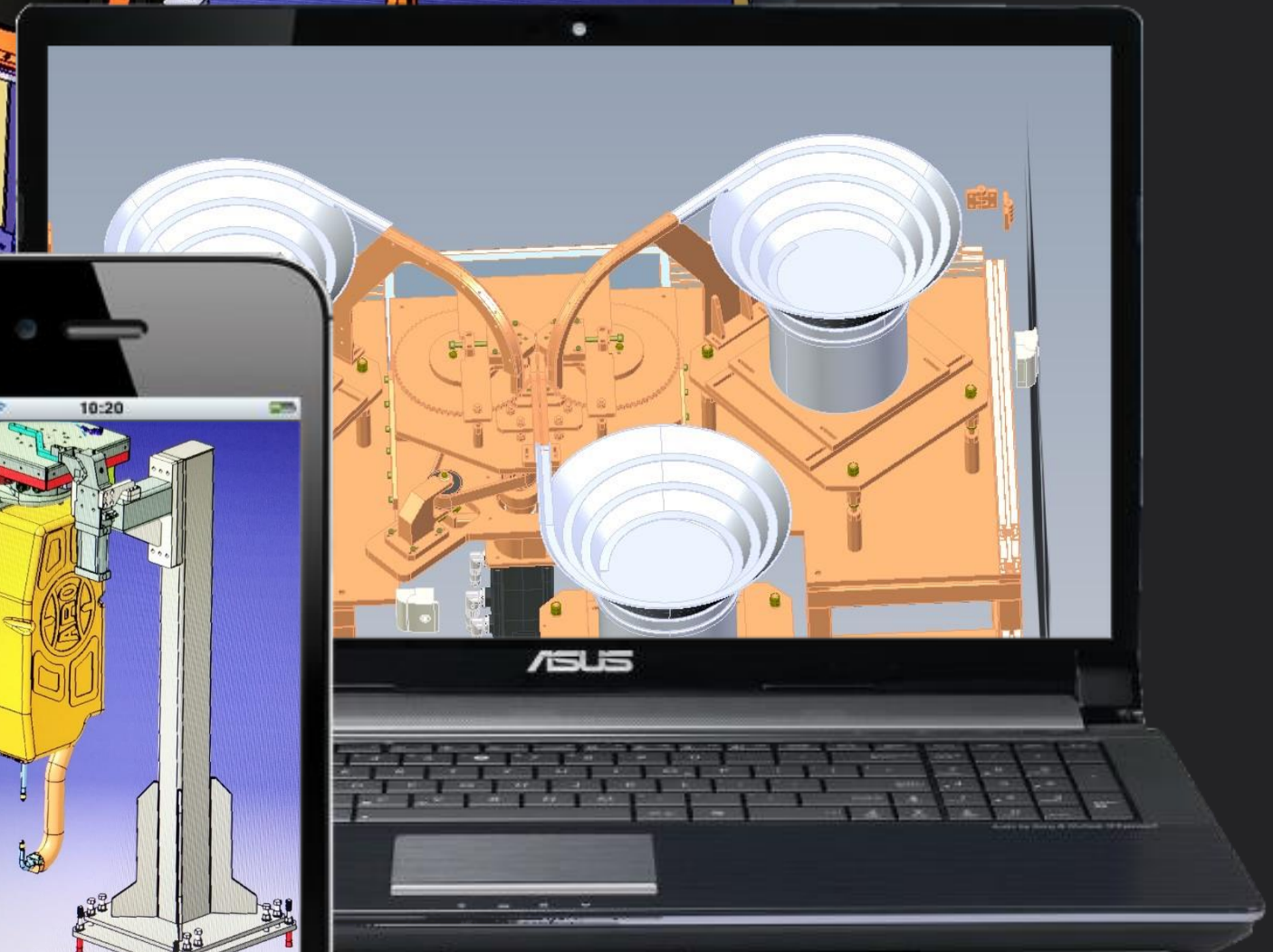
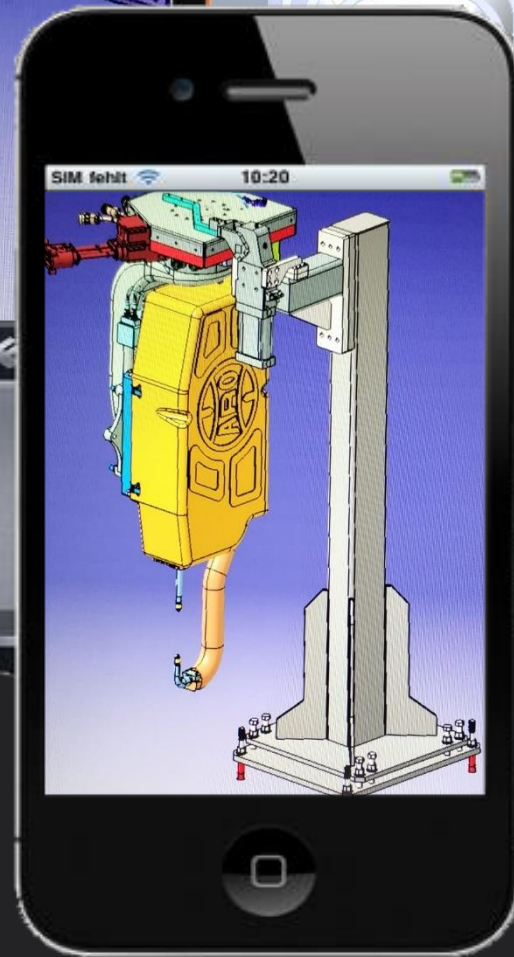
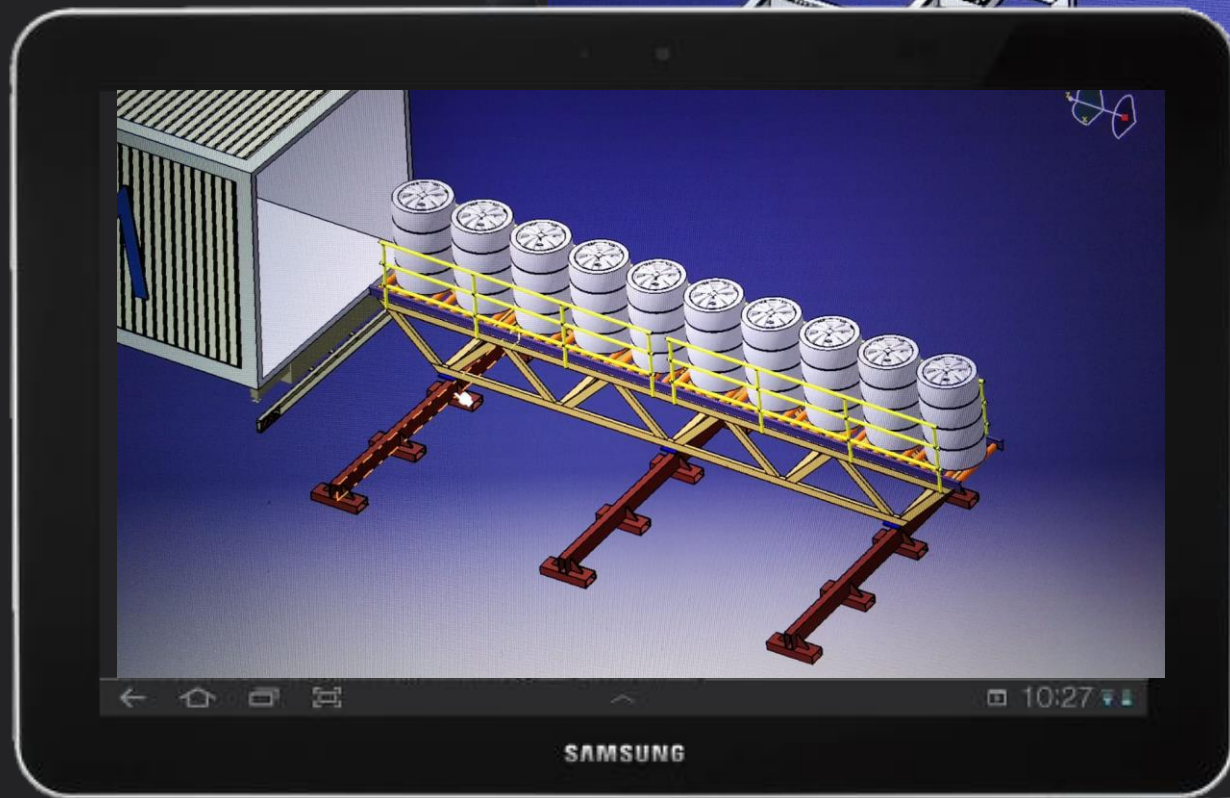
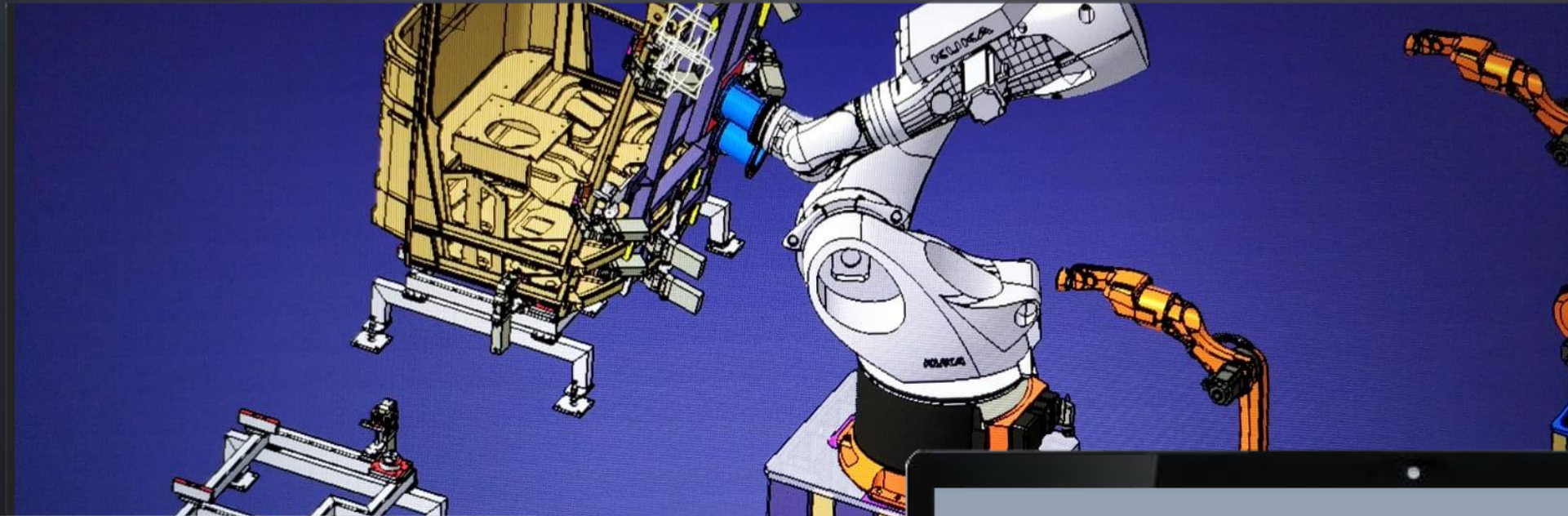

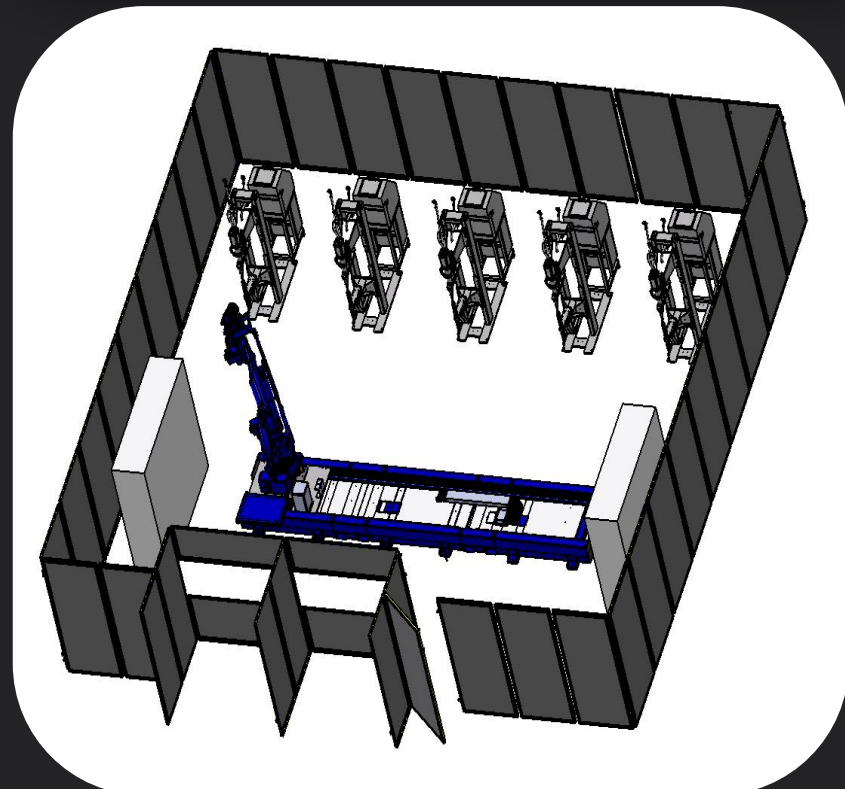
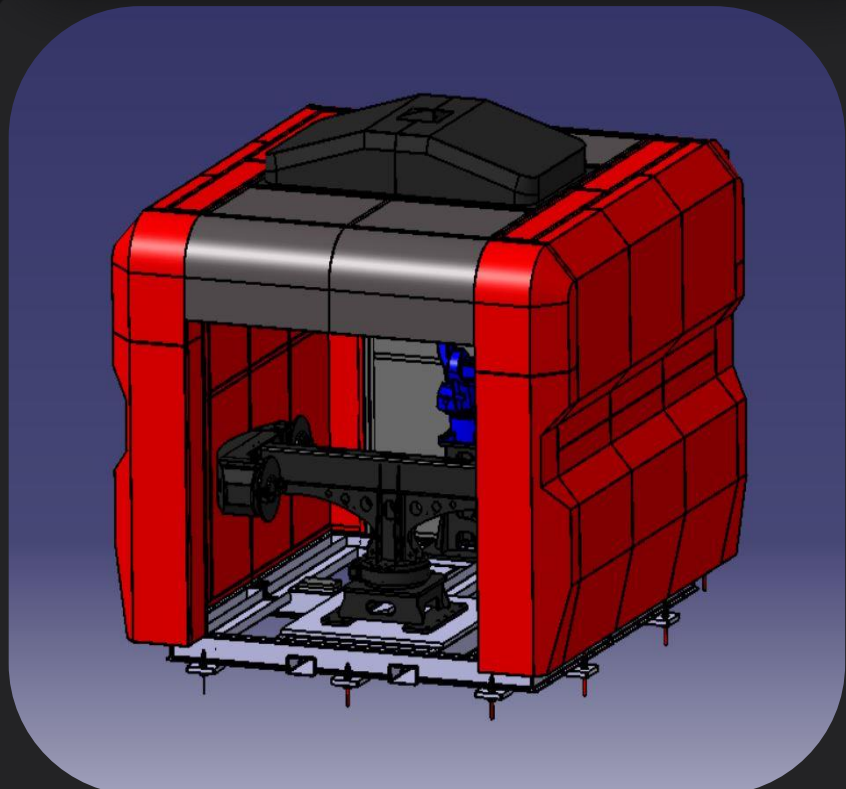
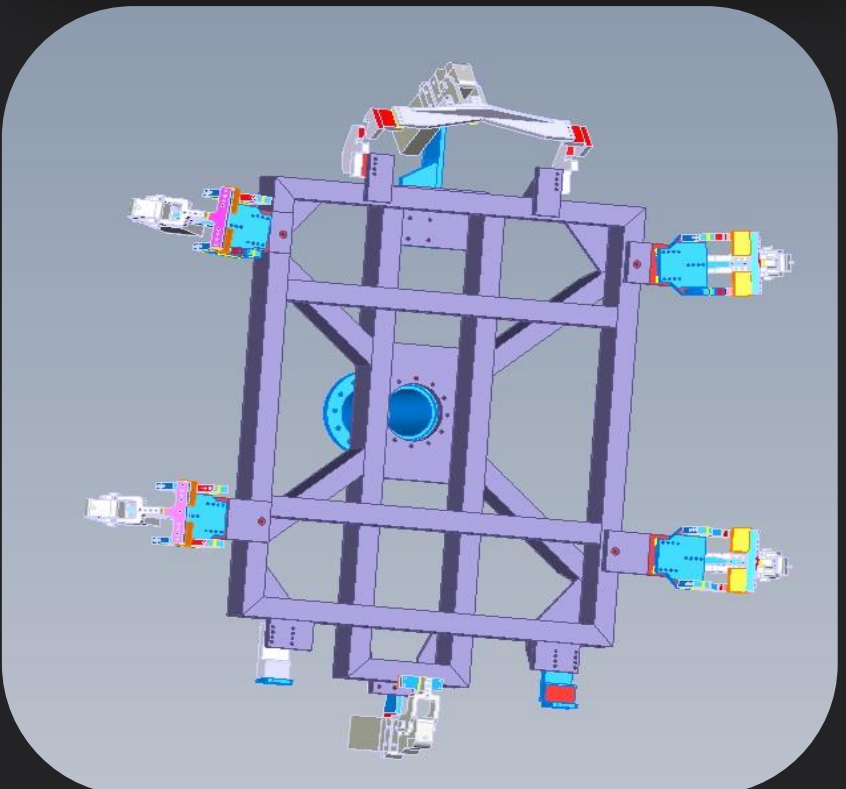
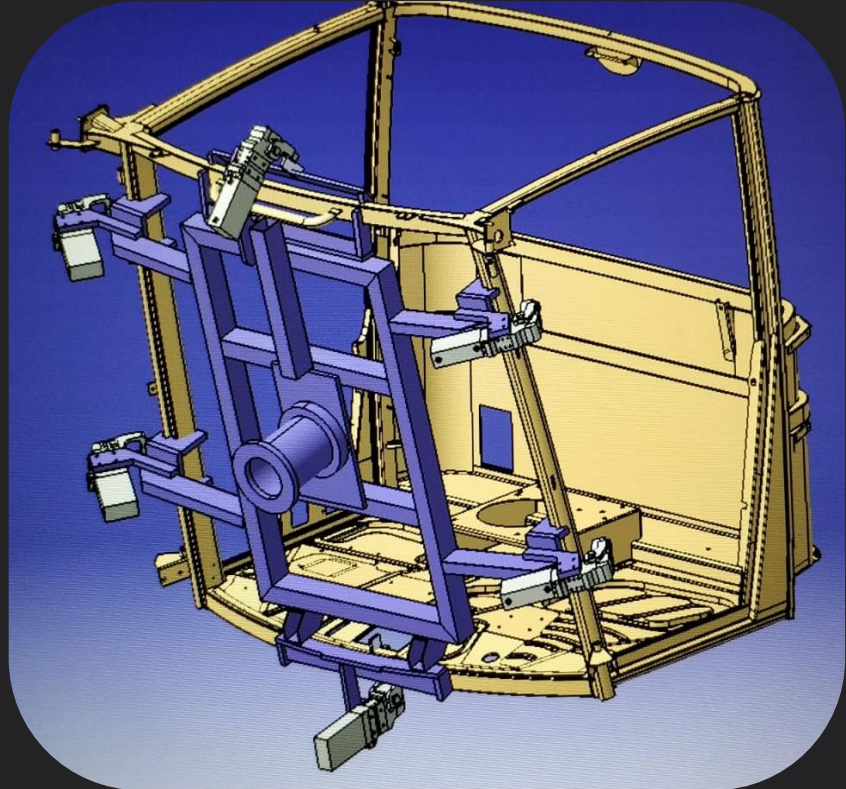
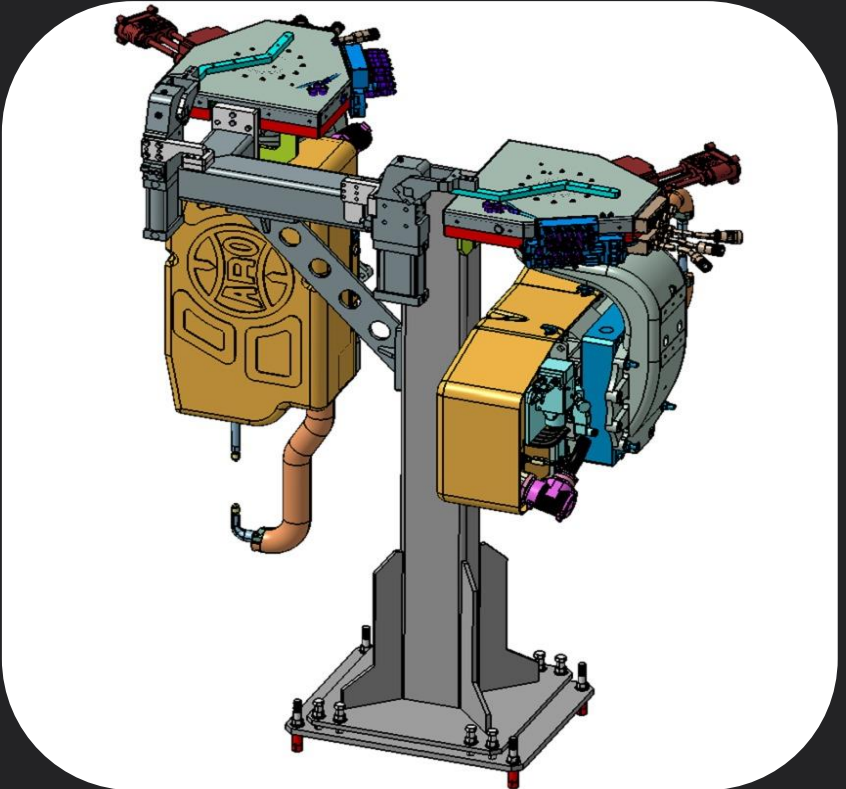
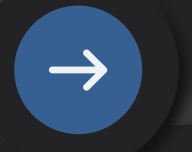



Ecomak olarak,

kaynaklı imalat konusunda yılların tecrübesi, konusunda uzman personeli, yoğun sipariş durumlarında 7/24 vardiya sistemi ile çalışan işletme yapısı ve kaliteden ödün vermeyen hizmet anlayışı ile siz değerli müşterilerimize kaynaklı imalat konusunda hizmet sunmaktayız.





Talaşlı İmalat

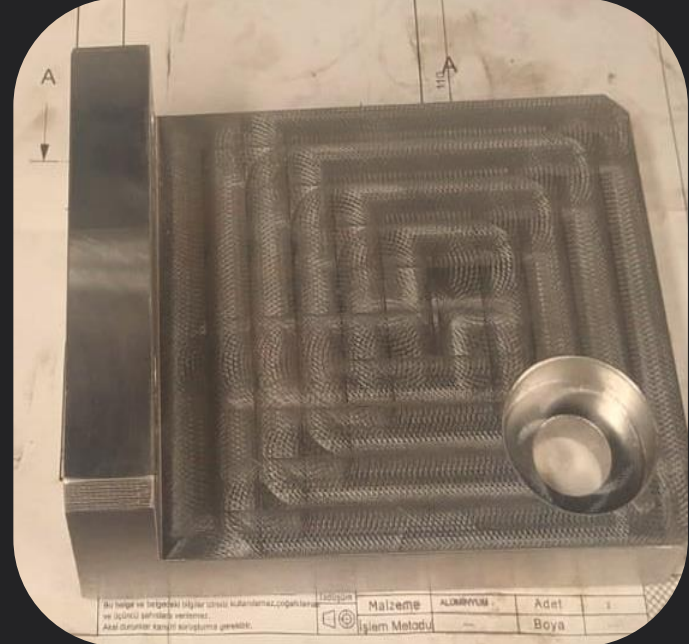
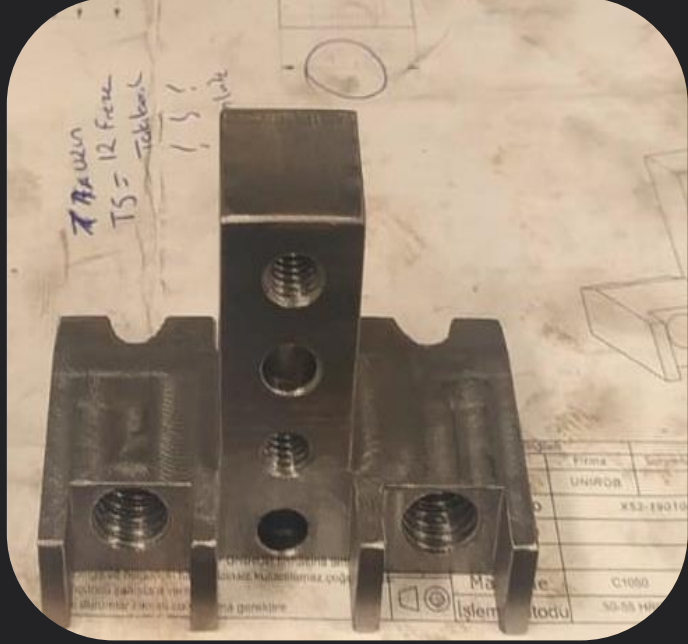

Ekomac olarak,

Otomotiv Yan Sanayisi için parçalar üretiyoruz. Otomotiv sektörünün ihtiyaç duyduğu yedek parça üretimlerini kalite standartları ile gerçekleştiriyoruz.

Metal kesme, CNC işleme ve tornalama, frezeleme, delik delme, çapak alma ve universal torna tezgahları ile hizmet vermekteyiz.

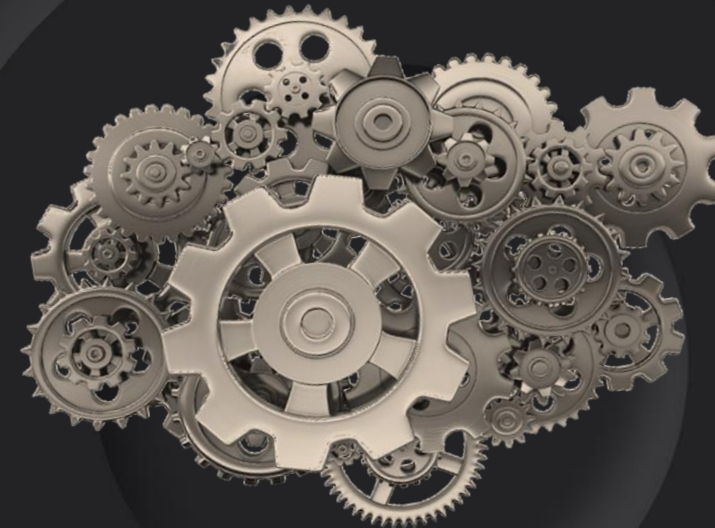



Havelsan. Boeing
737-800 NG Uçak
Simulatoru Montaj

Ecomak,

montaj hizmetlerinde sektöründe söz sahibi olmayı hedefleyen bir kuruluştur. Sürekli büyüyen referans yelpazesi, montajlarını bize teslim edip memnun kalan müşterilerimiz bu hedefe ulaşmamızdaki en büyük destek noktalarımızdır. Montaj çalışmalarımız müşterilerin isteklerine göre en uygun şekilde projelendirilip, montaj sürecini bu projeye uygun olarak titiz bir çalışmayla tamamlanır, kalite kontrol ekibimizce son kontrolleri yapılarak teslim edilir.

Yaptıklarımız

- 2019 Renault Türkiye: 27 Robotlu Kapı Mastik Hattı Kurulumu
- 2020 Renault Türkiye: 12 Robotlu Üretim Hattı Taşması
- 2020 Yarış Kabin Türkiye: 3 Robotlu Gazaltı Kaynak Hücresi Kurulumu
- 2021 Yarış Kabin Türkiye: 2 Robotlu Punta Kaynak Hücresi Kurulumu

“ BİZİM EKİP ”



Rasim SARIŞIN

Genel Müdür



İmalat

8 İmalat Personeli



Tasarım

2 Tasarım Personeli



Montaj ve Şantiye Kurulum

25 Montaj Personeli



Otomasyon ve Yazılım

8 otomasyon Personeli

Fabrikamızdan

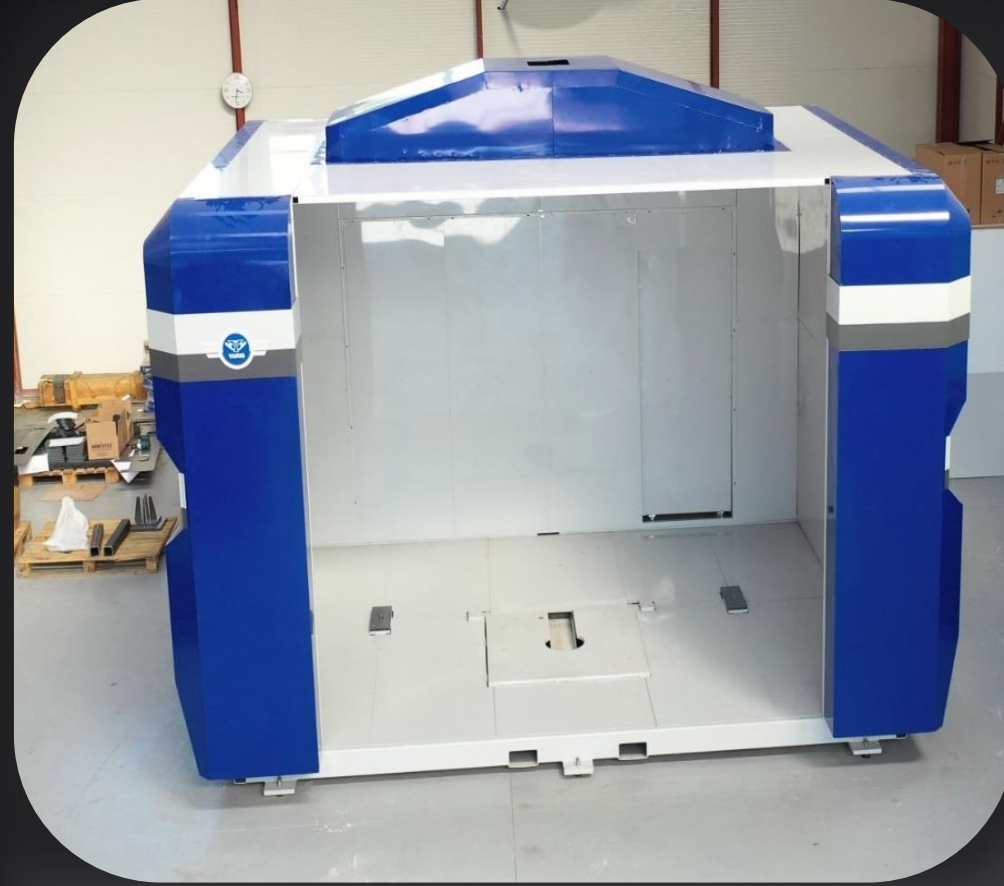

İletişim

ECOMAC



Yaylacık mah. 506.isimsiz sokak no 3
Nilüfer / BURSA



Teşekkürler!



Web sitesi:

www.ecomakmakina.com



Telefon:

0553 062 47 40



E-posta:

info@ecomakmakina.com

